

THE EFFECT OF HARMONIC DISTORTION TO POWER FACTOR

Dultudes Mangopo¹, Ekawati M. Ohee², Aris Sampe³, Theresia Wuri Oktaviani⁴, Rosalina N. Revassy⁴

^{1,2,3,4} Faculty of Engineering / Cenderawasih University/Indonesia
Email: elektro_doel@yahoo.com

Info Artikel

Histori Artikel:
Diterima 15 03, 2025
Direvisi 28 04, 2025
Disetujui 15 05, 2025

ABSTRACT

Harmonics are parts of power quality problems. According to the definition, harmonic is sinusoidal component of the wave period having frequency being equal to integer multiplication of fundamental component frequency value. Generally, the non sinusoidal waveform at voltage and current which is present in the distribution line, are caused by nonlinier load. Harmonic will be a problem when it is value exceeds related standard. This research was to analysis the effect of harmonic distorsion to power factor, total voltage harmonic and the total current harmonic distorsion on every distribution bus and every branch. This kinds of nonlinier loads is 12 pulse converter. Simulation was carried at using EDSA (Electrival Distribution and Transmission System Analysis). The configuration of test system was consist of a - 24 bus balance industrial distribution system. The harmonic sources were injected at bus 201. The research result showed that the largest harmonic voltage distortion was in the bus 201 with THD_V of 2.62% and which power factor of 0.75 and the THD_V smallest was in the bus 50 with the value of the THD_V as big as 0.48% and the power factor of 0.91. While biggest harmonic current distortion was in the bus 201 with THD_I value of 22.76% and the power factor of 0.77 and value THD_I smallest found in the bus 50 with THD_I value as big as 0.41% and has power factor of 0.90. After evaluated standardly IEEE 519-1992 the value THD_V and THD_I that produced being to still under standard limit. The result analysis showed that there was some effect of harmonic distortion to power factor. This matter was visible from the power factor value that produced low average low that caused by nonlinier load existence that contained harmonic in components or industrial devices.

Keywords: 3-6 keywords, keywords 1, keywords 2, Keywords 3

Penulis Korespondensi:

Dultudes Mangopo,
Department of Electrical Engineering, Faculty of Engineering,
Cenderawasih University,
Email: elektro_doel@yahoo.com

1. INTRODUCTION

Harmonic is not a new problem for industrial energy system and electricity user. Study and research about harmonic problem has been started since the year 1920.

In general, electric load a lagging power factor or leading one. Such as computer, printer, flourentcent lamp that use ballast elektronik, induction motor, etc. If it is needed reactive power the power factor very big become smaller, while the decrease it power factor will causes various losses in consumer side or load.

The effect of harmonic in electric power distribution system depends on harmonic source, harmonic source location and network characteristics. In order effort good efficiency of operation system and electric power utilization, the effect harmonic should necessary be calculated. In this writing it is discussed the effect of harmonic distortion to power factor in electric power distribution system.

2. BASIC THEORY

At the increase of harmonic content in electricity network, the assumption that current and voltage in electricity network always stay in ideal condition, can not be used anymore. The

measurement of power and power factor as a result, becomes more difficult. Because with the existence of harmonic, a simplified calculation can not be used.

2.1 Electricity Power Quantity

It is found three electricity power quantity those are :

1. Apparent power (S), is the multiplication of rms voltage and current.
2. Active power (P), is average value of energy that sent.
3. Reactive power (Q), is part of apparent power that has different phase angle of 90° to active power.

2.2 Power Factor In A Ideal Condition

Power factor is defined as:

$$PF = \frac{P}{S} \dots\dots\dots(2.1)$$

The quantity of P and S can always be easily calculated although is a very severe distorted waved, either through analytical calculation or through also with numerical computation using computer. In an ideal condition where voltage and current only consists of fundamental frequency components (example 50 hz), P detectable with similarity that familiar as follows:

$$PF_1 = \frac{\frac{V_1 \cdot I_1}{2} \cos \theta_1}{V_{1rms} \cdot I_{1rms}} = \cos \theta_1 \dots\dots\dots(2.2)$$

2.3 Power factor in a harmonic condition

Apparent power and reactive power are two very related quantity to harmonic distortion. Apparent power (S) may be evoked by load toward thermal ability system. It's value in proportion to current distortion quantity. in a condition that voltage and current are even very distorted if can be easily determined. When found of harmonic distortion is in a system, however harmonics analyser has not yet compromised to definit reactive power (Q). This different opinion will confuse many people electricity companies measure Q quantity and calculate the energy claimed based on power factor calculation based on value Q measured. In a ideal condition, energy trilateral concept as follows :

$$S = \sqrt{P^2 + Q^2} \dots\dots\dots(2.3)$$

S and P can easily be found even in a condition very distorted even if, conventional value of Q

(VAR) determined as $Q = \sqrt{S^2 - P^2}$ (2.4)

When above equation on applied on electricity energy system with big contents of harmonic, it will not match . This matter is relates to fact that VAR is :

$$Q = V_1 I_1 \sin \theta_1 \dots\dots\dots(2.5)$$

In most cases measurement found that a electronic equipment phase difference between voltage wave and current is very small ($\cos \approx 1$), but substitution to power factor equation shows that equipment has in PF small (far under one). This result is :

$$\sqrt{S^2 - P^2} - Q^2 \neq 0 \dots\dots\dots(2.6)$$

Experts had the same opinion that the an defined quantity was called with distortion power (D), with unit volt-amperes as follows :

$$\sqrt{S^2 - P^2} - Q^2 = D \dots\dots\dots(2.7)$$

so that power factor (cos) after harmonic existence .

$$\cos \varphi = \frac{P + D}{S} \dots\dots\dots(2.8)$$

2.4 Harmonic Of Defenition

In this case that mean with linear load electricity load the work behaviour doesn't causes to change it waveform sinusoidal (in fundamental frequency 50 hz). From system supplies ac. while load nonlinear electricity load that get to supply power from network system, but will causes system waveform will supply ac not sinusoidal pure again.

2.5 Harmonic Sources

The use of semikonduktor component such as diode and Thyr thyristor electricity energy conversion effort that worn in converter device, inverter and the others with electronics device that used for electromotor rotation speed arrangement shows more rapidly grow the use.

2.6 Harmonic In Three Phase System

In three phase system, harmonic that produced same like system one fasa, for that calculation is done in the same way. Even harmonic usually is ignored because this harmonic result with fundamental component produces symmetrical waveform in area axis kompleks. in three phase system harmonic analysis, harmonic is reviewed from symmetrical component. Third harmonic with the multiple (triplen harmonic), although this harmonic not so big, but the existence in system necessary payed.

2.7 Harmonic distortion calculation

In the harmonic effect testing especially in energy system, it is used total harmonic distortion (THD), defined as percentage of harmonic component total to the fundamental component. Distortion harmonic total (THD) can be inscribed as follows:

$$THD = \frac{\sqrt{\sum_{n=2}^k U_n^2}}{U_1} \times 100\% \dots\dots\dots (2.9)$$

with :

- Un = harmonic component
- U₁ = fundamental component
- k = maximum harmonic component

3. RESEARCH OF METHOD

The data that are used in this research consisting of two kinds. First, numerical data of an electric power system that consist of transformer, load, harmonic current spectrum due to nonlinear load and single line diagram of system. To be more valid, this research involving case data example of IEEE: balance distribution system 24 - bus a industrial (sergio l. et al, 2004). Second, harmonic voltage measured were compared to THD_v of an electric power system produced in program made in this research.

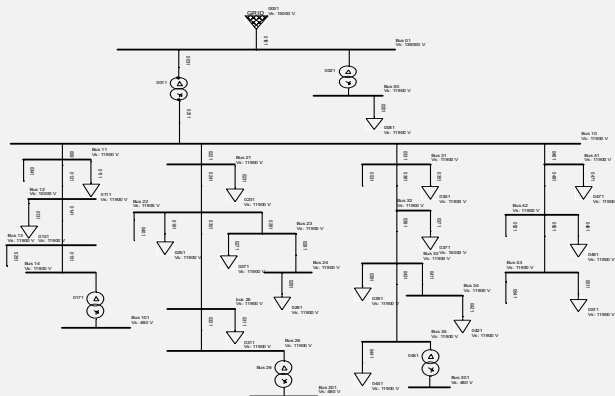

Fig. 1 Single line diagram of system IEEE test system distribution industrial 24 bus balance system

4. RESULT AND DISCUSSION

The effect of harmonic distortion to power factor in electric power distribution system can be seen at every bus by the use of EDSA program. Figure 2, shows distorted voltage waveform at bus 50, while harmonic voltage magnitude is shown in fig 3. The distorted sinusoidal current waveform at bus 50 is expressed in fig 4 and its magnitude of current harmonic is shown in fig 5

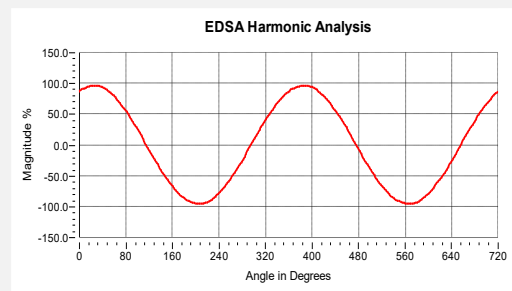

Fig 2 Distorted voltage waveform at bus 50

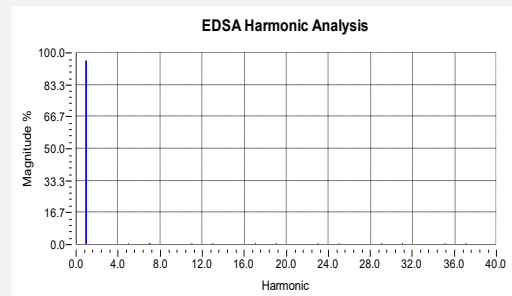

Fig. 3 Component harmonic voltage magnitude at bus 50

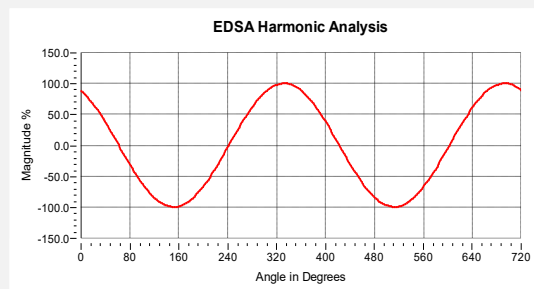

Fig 4 Distorted Current Waveform at Bus 50

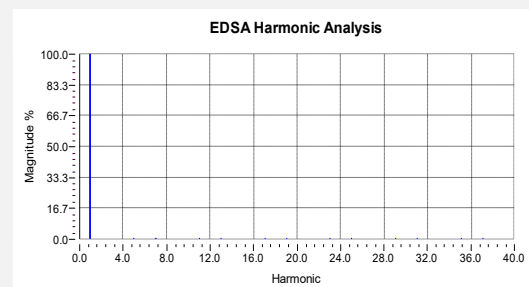

Fig 5 Magnitude harmonic current component at bus 50.

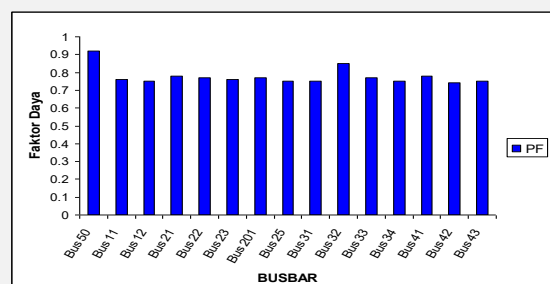

Fig 6 The effect of harmonic source at bus 201 to factor power at various busbar

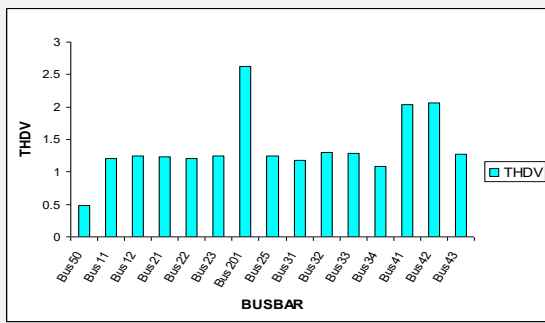

Fig. 7 The effects of harmonic source at bus 201 to THDV at various busbar

4.1 Analysis of result

Figure 6 shows that the largest power factor, which is 0.9 at bus 50. According the single line diagram, Fig 3.1, bus 50 has the longest distance from bus 201, at which the harmonic source is located. Therefore, certainly bus 50 has the smaller flow of harmonic current Fig 7. It can also be see at that figure that at other buses have only small effect to the harmonic source located at bus 201. Futher, as the effect of the harmonic source at bus 201, bus 50 has the smallest value of THDV, which is 2.62%. This value is still lower than 5%, the normal standard according IEEE 519-1992. Due to small value of at bus THDV at bus 50, the power factor at that bus is high, 0.9.

In the point of view of the effect of harmonic in term of THDI at various bus it in clear. That bus 201 has the largest value of THDI, 22.76%, Figure 7 and power factor, 0.77, Figure 4.6. This condition is due to the location of harmonic source being at bus 201. Definitely the bus 201 THDI value is greater than 5%, mentioned by the standard of IEEE 519-1992. However the THDI at other buses except bus 25 having the range of 0.41%-5.32% that of the standard. In the effect to power factor, nearly all buses are affected by harmonic distortion. This is clear at bus power factor, which has average of 0.74 up to 0.86

5. KESIMPULAN

- 1) Bus will harmonic source has the largest values of THDV and THDI and the smallest value of power factor. Bus 201, in this case, has THDV of 2.62% and power factor of 0.71. Futher it's THDV is 22.76% and power factor of 0.77
- 2) Bus the longest distance from the harmonic source has the smallest effect due to harmonic. In this case bus 50 has THDV of 0.48% and has a power factor

of 0.91, which its THDI of is 0.41% and its power factor is 0.91.

DAFTAR PUSTAKA

- [1] Arrilaga J. et.al., "Power System Harmonics", New Delhi : John Wiley & Sons, 1985
- [2] Danny Chretien et.al., "Power Factor Correction and Harmonic Control for dc drive Loads", 1993
- [3] Fang Zheng Peng et.al., "Harmonic and Reactive Power Compensation Based on the Generalized Instantaneous Reactive Power Theory for Three-Phase Four-Wire Systems", IEEE Trans. on Power Electronics, vol.13 no.6, Nov. 1998
- [4] Fang Zheng Peng, et.al., "A New Approach to Harmonic Compensation in Power Systems - A Combined System of Shunt Passive and Series Active Filters", IEEE Trans. on Industry Appl., vol.26 no.6, Nov/Dec. 1990
- [5] Gonen, T., "Electric Power Distribution system Engineering", McGraw-Hill Book Company, pp: 442-448, 1986
- [6] Mack Grady, dan Robert Gilleskie, , "Harmonic and How They Relate to Power Factor", 1993.
- [7] Jeldres, J.V, dan Guilermo, P.V, "Control of Harmonics and Power Factor Improvement", IEEE Trans on Power System, 1996.
- [8] Joseph Subjak et.al., "Harmonics - Causes, Effects, Measurements and Analysis" : An Update, IEEE Trans. on Industry Appl., vol.26 no.6, Nov/Dec, 1990
- [9] Jusmin Sutanto, "Analysis of Reactive Power Compensation for Electric Energy Compensation" : Nonlinear Loads Constraint, Spektrum Politeknik Negeri Bandung, Oct. 2001
- [10] Kawann, C, dan Emanuel, A.E, 1996, "Passive Shunt Harmonik Filters for Low and Medium Voltage, a cost comparison study", IEEE Trans and Power System, vol.11, no.4, pp: 1825-1831.
- [11] Nababan, S, "Tapis Paralel Pasif untuk Mengurangi Distorsi Harmonik Beban Tak Linier; Pemodelan, Analisis, dan Desain", Tesis, Program Pascasarjana Program Studi Teknik Elektro UGM, Yogyakarta, 2001